



Code Compliance Research Report

CCRR-0100

Subject to Renewal: 05/31/2011
Visit www.archtest.com for current status

Issued: 05/31/2009
Page 1 of 6

Mid Atlantic Vinyl Products, Inc.
5109 Commonwealth Drive
Fredericksburg, Virginia 22407

1. Subject

Weatherwise™ Vinyl Railing

Also identified as *Pro-Rail*® Vinyl Railing

Baltimore, Windsor, Fairfield, Brookfield, Kenmore, Charleston, Manchester, and Lexington Vinyl Guardrail Assemblies (Guards)

2. Research Scope

2.1 Building Codes:

2003 and 2006 International Building Code (IBC)

2003 and 2006 International Residential Code (IRC)

1999 BOCA National Building Code

2007 Florida Building Code (FBC)
(Excluding the High Velocity Hurricane Zones)

2.2 Properties:

Structural Performance

Durability

Surface Burning

3. Description

3.1 General - *Weatherwise*™ vinyl railings are guardrails or guards under the definitions of the referenced codes intended for use on elevated walking areas in buildings and walkways as required by the codes. Guard systems are provided as level guards for level walking areas such as decks, balconies and porches, and sloped guards for open sides of stairways.

3.2 Materials and Processes - *Weatherwise*™ vinyl railings are an assemblage of extruded and molded components utilizing white Poly Vinyl Chloride (PVC) material with aluminum reinforcements and aluminum mounting brackets. All systems consist of the following components:

3.2.1 Top rails are either a T-Rail 3.5" wide at the top, 2" wide at the bottom and 3.5" tall or a rectangular profile 2" wide by 3.5" tall.

3.2.2 Bottom rails in all systems are a 2" wide by 3.5" tall rectangular profile.

3.2.3 Balusters are 1.5" square and come in two styles. Pickets are 1.5" square throughout its length. Spindles are 1.5" square at the ends and blow molded to form a turned spindle shape through the mid-section of the length.

3.3 Level 42-Inch High Guards - The *Baltimore, Windsor, Fairfield, and Brookfield* series are intended to serve as 42-inch high guards up to 10-feet in length for use in all residential use groups.

3.3.1 An extruded aluminum insert provides reinforcement in the top and bottom rail. A secondary extruded aluminum insert is used in the top rail for railing lengths exceeding 8-feet.

3.4 Level 36-Inch High Guards - The *Kenmore, Charleston, Manchester, and Lexington* series are intended to serve as 36-inch high guards up to 10-feet in length for use only in One- and Two-Family Dwellings.

3.4.1 An extruded aluminum insert provides reinforcement in the top and bottom rail.

3.4.2 Bottom rails have an intermediate support located at mid-span.

3.5 Stair rails have an overall assembly height of approximately 36 inches projected vertically to the walking surface and have a maximum rail length of 8-feet.

3.5.1 All components utilized in the stair rail assembly are the same as those utilized in the corresponding level rails with the exception of the baluster length.

3.5.1.1 Routed baluster holes in the PVC stair rail sections are elongated to 1.9" to allow the baluster to rotate corresponding to the slope of the stair.

3.6 Top and bottom rails are connected to posts using aluminum brackets secured to the posts with stainless steel wood screws.

3.7 *Weatherwise*™ vinyl railings are supported with 4x4 PVC posts installed over an UltiMount™ ProSpec post mount system or conventional wood post. Code compliance assessment of conventional wood posts is not within the scope of this report. See 7. Conditions of Use for further limitations.

4. Performance Characteristics

4.1 *Weatherwise*[™] vinyl railings have demonstrated their capacity to resist the design loads specified in Chapter 16 of the IBC and BOCA codes when tested in accordance with ICC-ES AC174.

4.2 Materials used to produce *Weatherwise*[™] vinyl railings are deemed equivalent to preservative treated or naturally durable wood for resistance to weathering effects, decay, and attack from termites.

4.3 PVC materials used have a flame spread index of 35 when tested according to ASTM E84. The reference criteria, AC174, requires a flame spread index not exceeding 200.

5. Installation

Installation shall be in accordance with the manufacturer's installation instructions and this report. Where differences occur between this report and the manufacturer's installation instructions, this report shall govern.

5.1 Railing assemblies consist of top and bottom rails with pre-routed holes to receive balusters. Aluminum railing reinforcements are inserted in the rails during assembly as specified for the series/model (see 3. Description).

5.2 Ends of stair rails must be field cut to provide a flush mount with the supports.

5.3 Aluminum brackets are secured to the support posts with three #12 by 1" long stainless steel wood screws.

5.4 Aluminum brackets are secured to the rails with two #8 by 3/4" long stainless steel wood screws.

6. Supporting Evidence

6.1 Manufacturer's drawings and installation instructions.

6.2 Reports of testing demonstrating compliance with ICC-ES Acceptance Criteria for Deck Board Span Ratings and Guardrail Systems (Guards and Handrails), AC174, approved February 2007, effective March 1, 2007.

6.3 Quality control manual demonstrating compliance with ICC-ES Acceptance Criteria for Quality Documentation, AC10, approved February 2007, Effective March 1 2007.

7. Conditions of Use

The guardrail assemblies identified in this report are deemed to comply with the intent of the provisions of the referenced building codes subject to the following conditions:

7.1 Guardrails are limited to use in residential use groups R3 and R4 of the IBC and FBC. 36-inch high guards are further limited to use in One- and Two-Family Dwellings (IRC).

7.2 Compatibility of fasteners, post mount brackets, and other metallic components with the supporting structure including chemically treated wood is not within the scope of this report.

7.3 The UltiMount[™] ProSpec post mount system utilized with 36" high guards may be mounted in a wood deck or anchored to concrete and/or steel with approved anchors. Installation in wood decks shall be in accordance with the manufacturer's installation instructions (see Figure 2).

7.4 The UltiMount[™] ProSpec post mount system utilized with 42" high guards shall be anchored to concrete and/or steel with approved anchors. Use in residential applications other than One- and Two-Family Dwellings is limited to supporting rail lengths up to and including 4-feet.

7.5 Post mount system anchors used in concrete/steel installation are not within the scope of this report and are subject to evaluation and approval by the building official. Anchors must satisfy the design load requirements specified in Chapter 16 of the building code and must meet the following minimum requirements:

7.5.1 A minimum of four anchor bolts must be used and located in the four pre-drilled holes in the post base plate.

7.5.2 The anchors must have a minimum nominal diameter equal to 5/16".

7.5.3 Where required by the building official, engineering calculations and details shall be provided. The calculations shall verify that the anchorage complies with the building code for the type and condition of the supporting construction.

7.6 All systems are manufactured in accordance with the manufacturer's approved quality control system with inspections by Architectural Testing, Inc. (AA-676).

8. Identification

Mid Atlantic Vinyl Products' *Weatherwise*™ Vinyl Railing produced in accordance with this report shall be identified with labeling on the individual components or the packaging that includes the following information:

8.1 The mark of the independent inspection agency, Architectural Testing, Inc. (AA-676)

8.2 The ATI Code Compliance Research Report Number (CCRR-0100)

9. Code Compliance Research Report Use

9.1 Approval of building products and/or materials can only be granted by a building official having legal authority in the specific jurisdiction where approval is sought.

9.2 Code Compliance Research Reports shall not be used in any manner that implies an endorsement of the product by ATI.

9.3 Reference to the Architectural Testing internet web site address at www.archtest.com is recommended to ascertain the current version and status of this report.

Table 1
IBC, FBC, & BOCA / All Residential Use Groups

<i>Baltimore, Windsor, Fairfield, Brookfield</i>	Level Rail	Stair Rail
Assembly Height ¹	40 Inches	36 Inches
Assembly Length	120 inches	96 inches
Top Rail Reinforcing	Aluminum "H" (Secondary alum. insert required for rail lengths exceeding 8-feet)	Aluminum "H"
Bottom Rail Reinforcing	Aluminum "H"	Aluminum "H"
Bottom Support Block	None	None

¹ Assembly height is bottom of bottom rail to top of top rail.

Table 2
FBC & IRC / One- And Two-Family Dwellings

<i>Kenmore, Charleston, Manchester, Lexington</i>	Level Rail	Stair Rail
Assembly Height ¹	34 Inches	36 Inches
Assembly Length	120 inches	96 inches
Top Rail Reinforcing	Aluminum "H" or Alternate "H" (see Figure 2)	Aluminum "H"
Bottom Rail Reinforcing	Aluminum "L"	Aluminum "L"
Bottom Support Block	One located mid-span	None

¹ Assembly height is bottom of bottom rail to top of top rail.

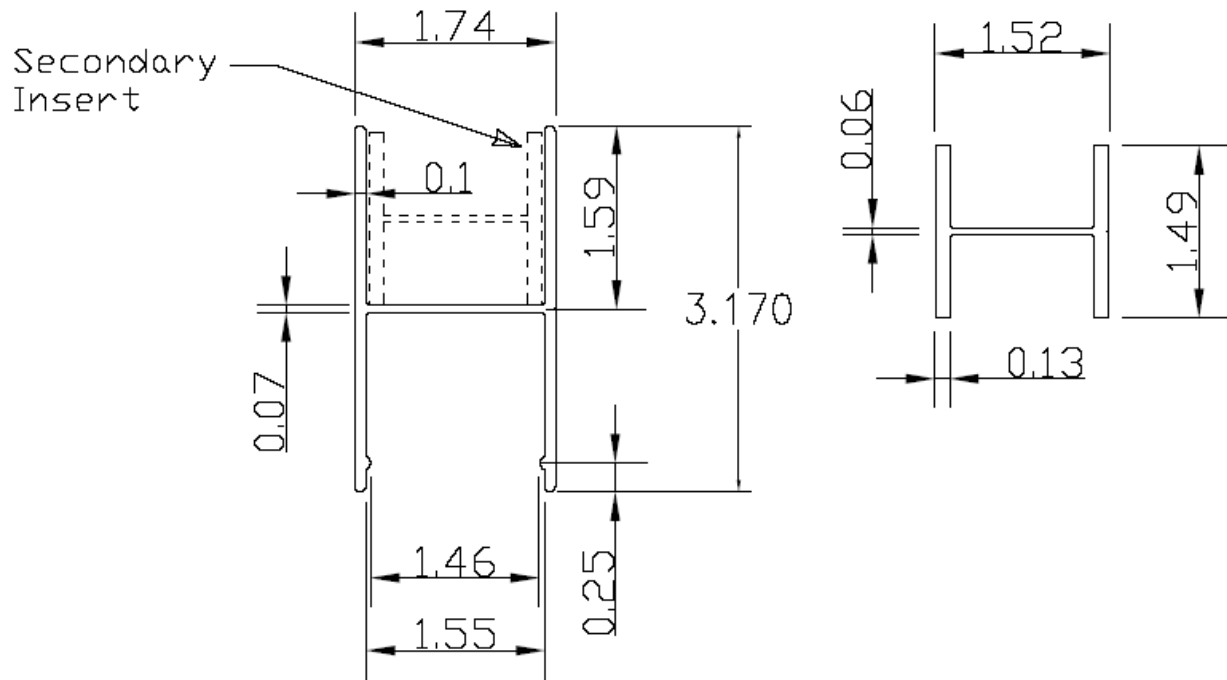

Figure 1 - Top Rail Aluminum Insert and Secondary Insert

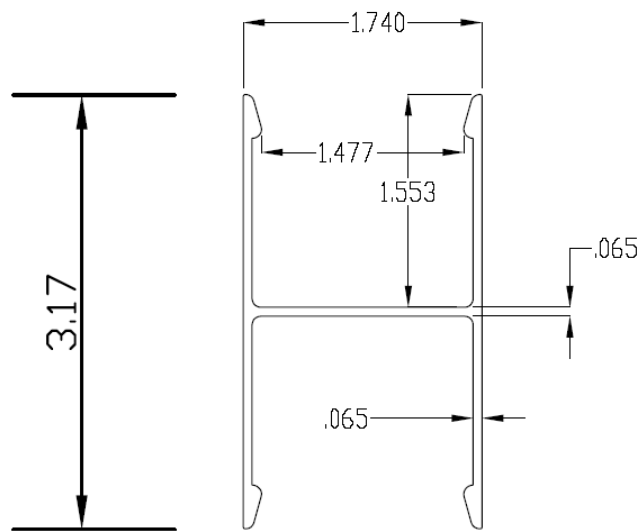

Figure 2 - Alternate Top Rail Aluminum Insert
(For Top Rail Only In Kenmore, Charleston, Manchester and Lexington)

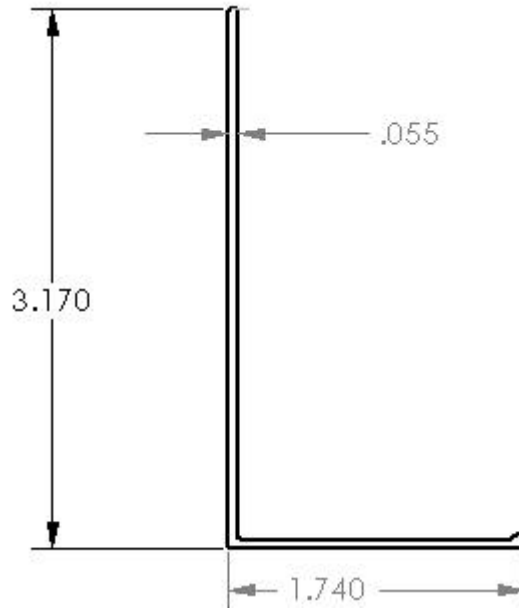

Figure 3 - Bottom Rail Aluminum Insert

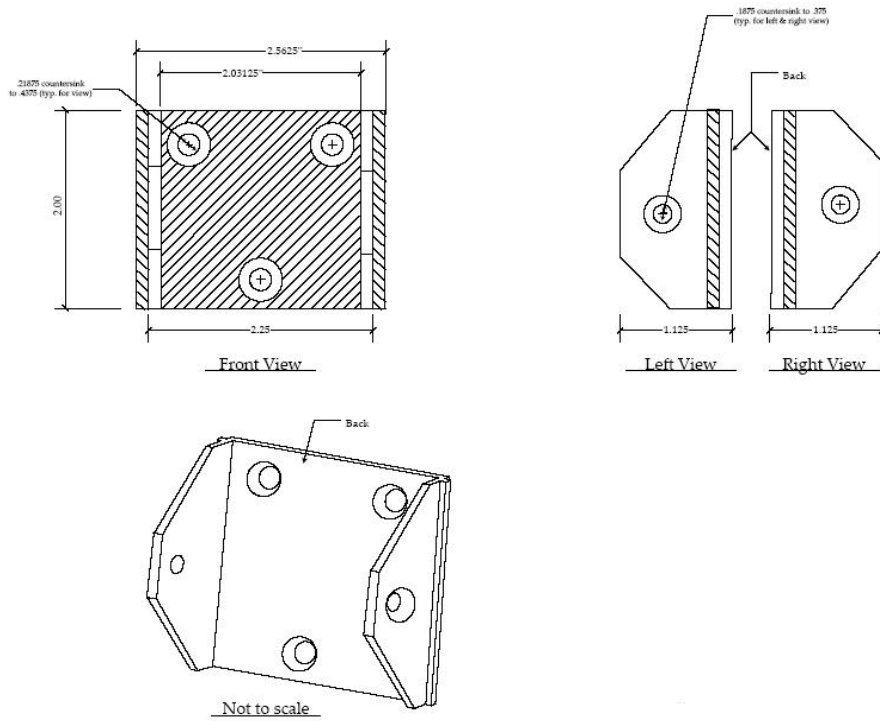

Figure 4 - Aluminum Rail Brackets

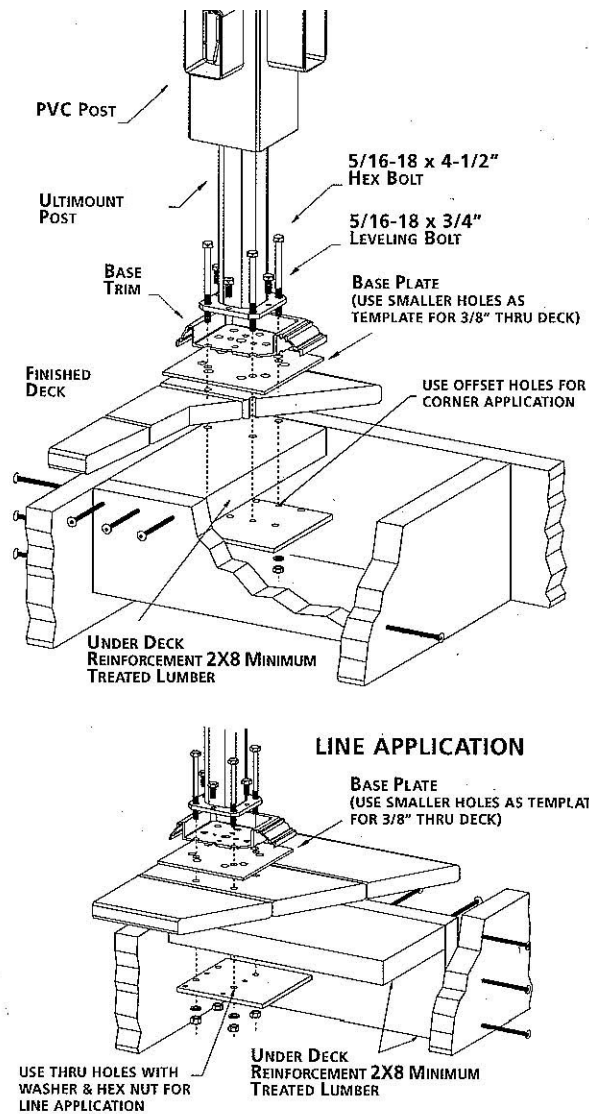

Figure 5 - UltiMount™ ProSpec Installation in a Wood Deck

Note: Fasteners shown for installation of 2x8 wood support blocking in the deck framing are #8x3" deck screws.